

NR.	Part	amount
1	Round post leg (anchor)	1
2	Plastic upper post cover	1
3	4051-Bottem profile	1
4	4075-Round post chanel's cover	2
5	4072- Round post with connection chanel's	1
6	4052- Blind profile (lambiri)	13
7	4050-Upper closing profile	1
8	Clips for 4050 upper closing profile	2

DIN 7168 TS 1980				NAME / İSİM	TARİH DATE	İMZA SIGNATURE	ÜRÜN KODU PRODUCT CODE	150 ALM 8888		
TOLERANS KALİTESİ TOLERANCE CLASS				ÇİZEN DRAWN BY	M.YILMAZTÜRK	9.08.2024	ÜRÜN ADI PRODUCT NAME			
BOYUTLAR DIMENSIONS	f (ince) f (fine)	m (orta) m (medium)	g (kaba) g (coarse)	KONTROL CHECKED BY	H.YILDIZ	9.08.2024	PARÇA KODU PART CODE	150 ALM 8888		
0.5-3 mm	±0.05	±0.1	±0.2	ONAY APPROVED BY	H.YILDIZ	23.09.2024	PARÇA ADI PART NAME	Genel Montaj		
3-6 mm	±0.05	±0.1	±0.3	Teknik Resim Kodu		PAGE/SAYFA	MALZEME MATERIAL	YÜZEY ALANI mm² SURFACE AREA mm²	21637115.34	SCALE/ÖLÇEK
6-30 mm	±0.1	±0.2	±0.5			1	Malzeme <belirli değil>	AĞIRLIK (gr) MASS (gr)	16404.60	1:20
30-120 mm	±0.15	±0.3	±0.8							
120-400 mm	±0.2	±0.5	±1.2							
400-1000 mm	±0.3	±0.8	±2.0							
1000-2000mm	±0.5	±1.2	±3.0							

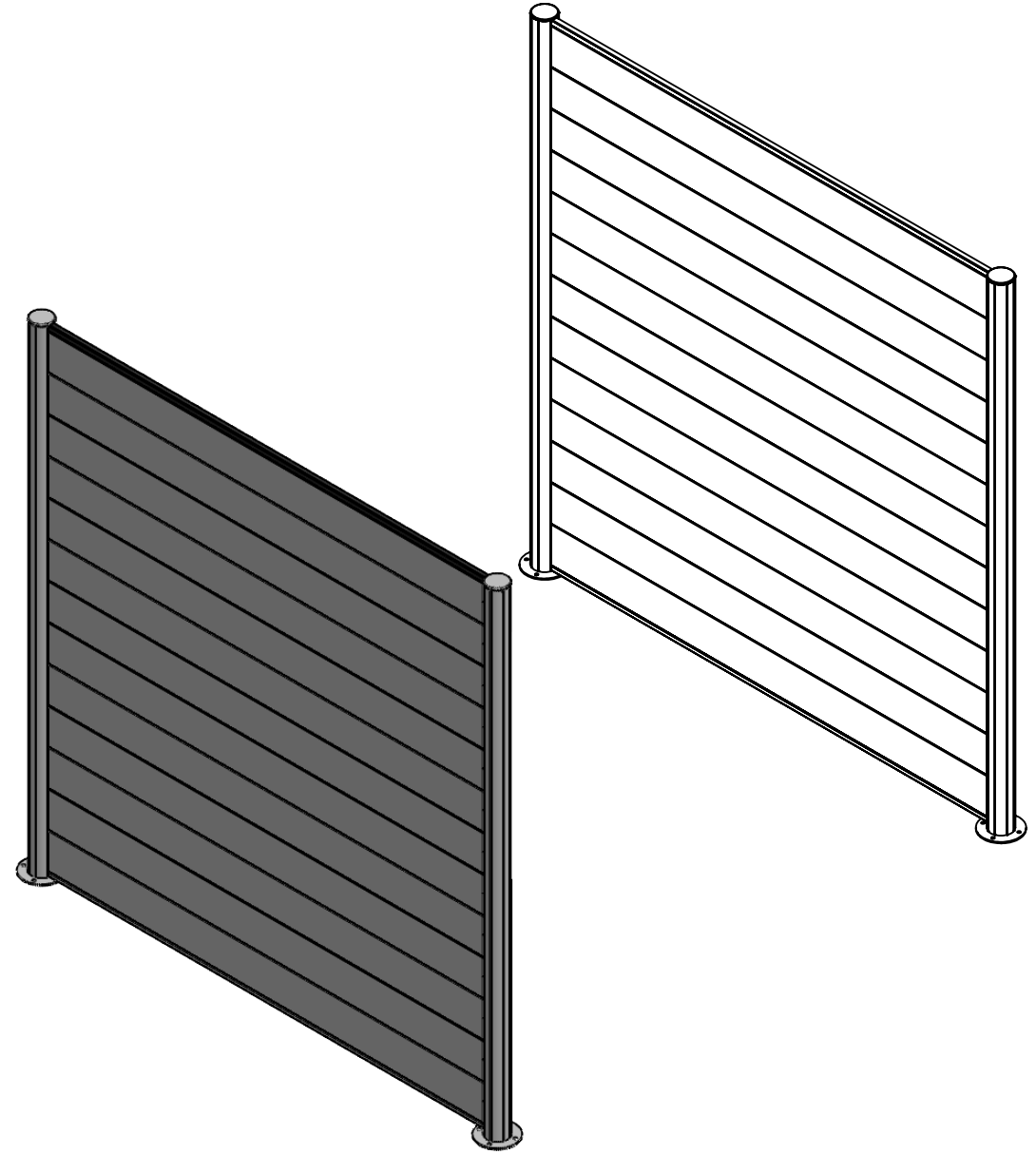

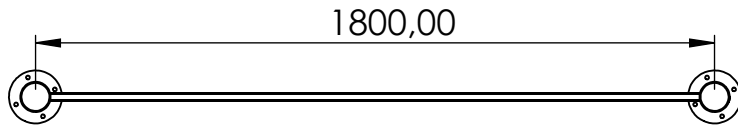

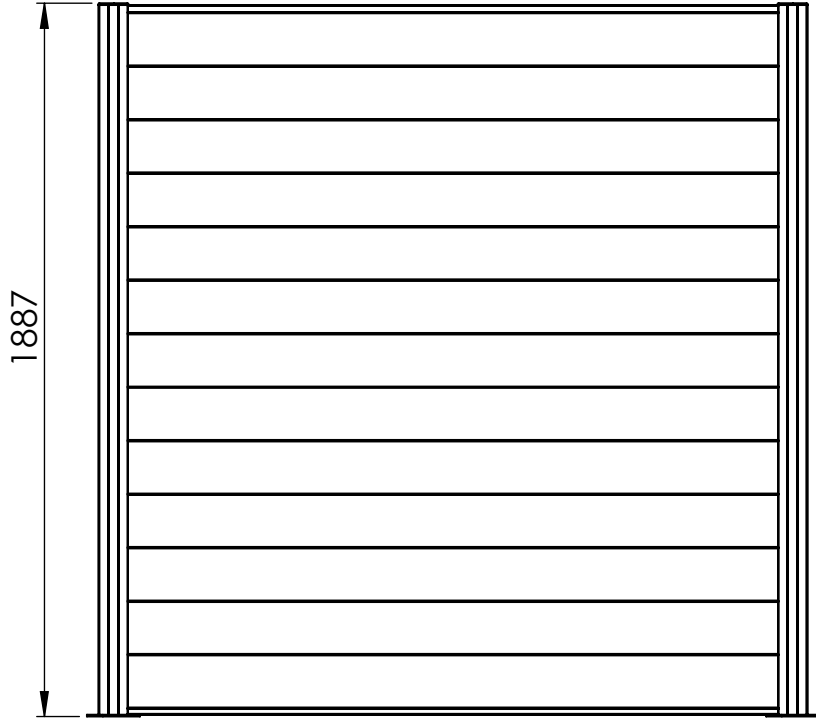

DIN 7168 TS 1980				NAME / İSİM	TARİH DATE	İMZA SIGNATURE	ÜRÜN KODU PRODUCT CODE		
TOLERANS KALİTESİ TOLERANCE CLASS				ÇİZEN DRAWN BY	9.08.2024		ÜRÜN ADI PRODUCT NAME		
BOYUTLAR DIMENSIONS	f (ince) f (fine)	m (orta) m (medium)	g (kaba) g (coarse)	KONTROL CHECKED BY	9.08.2024		PARÇA KODU PART CODE		
0.5-3 mm	±0.05	±0.1	±0.2	ONAY APPROVED BY	9.08.2024		PARÇA ADI PART NAME		
3-6 mm	±0.05	±0.1	±0.3	Teknik Resim Kodu		PAGE/SAYFA	MALZEME MATERIAL	YÜZEY ALANI mm² SURFACE AREA mm²	SCALE/ÖLÇEK
6-30 mm	±0.1	±0.2	±0.5			1		AĞIRLIK (gr) MASS (gr)	1:20
30-120 mm	±0.15	±0.3	±0.8						
120-400 mm	±0.2	±0.5	±1.2						
400-1000 mm	±0.3	±0.8	±2.0						
1000-2000mm	±0.5	±1.2	±3.0						

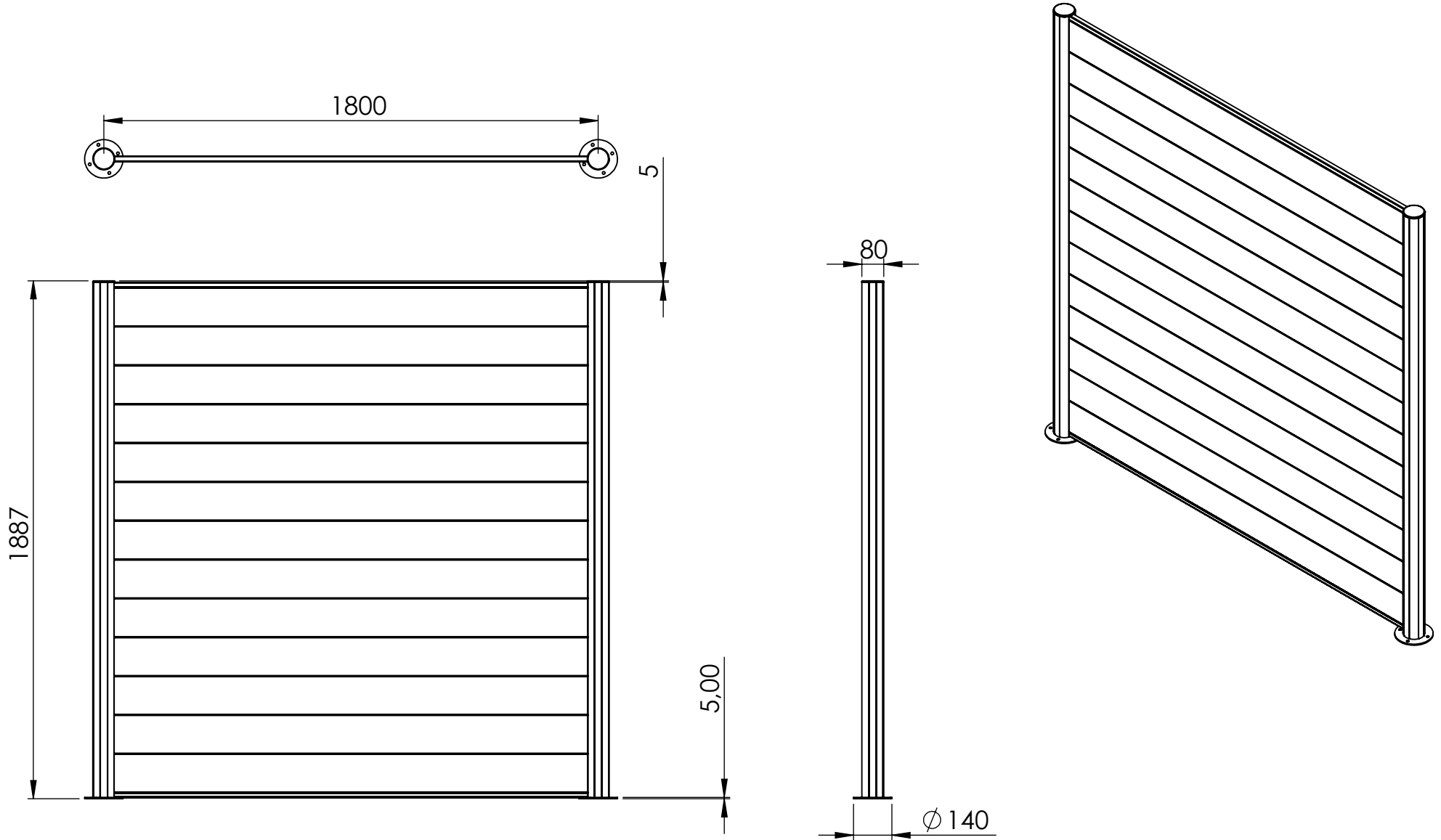

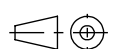

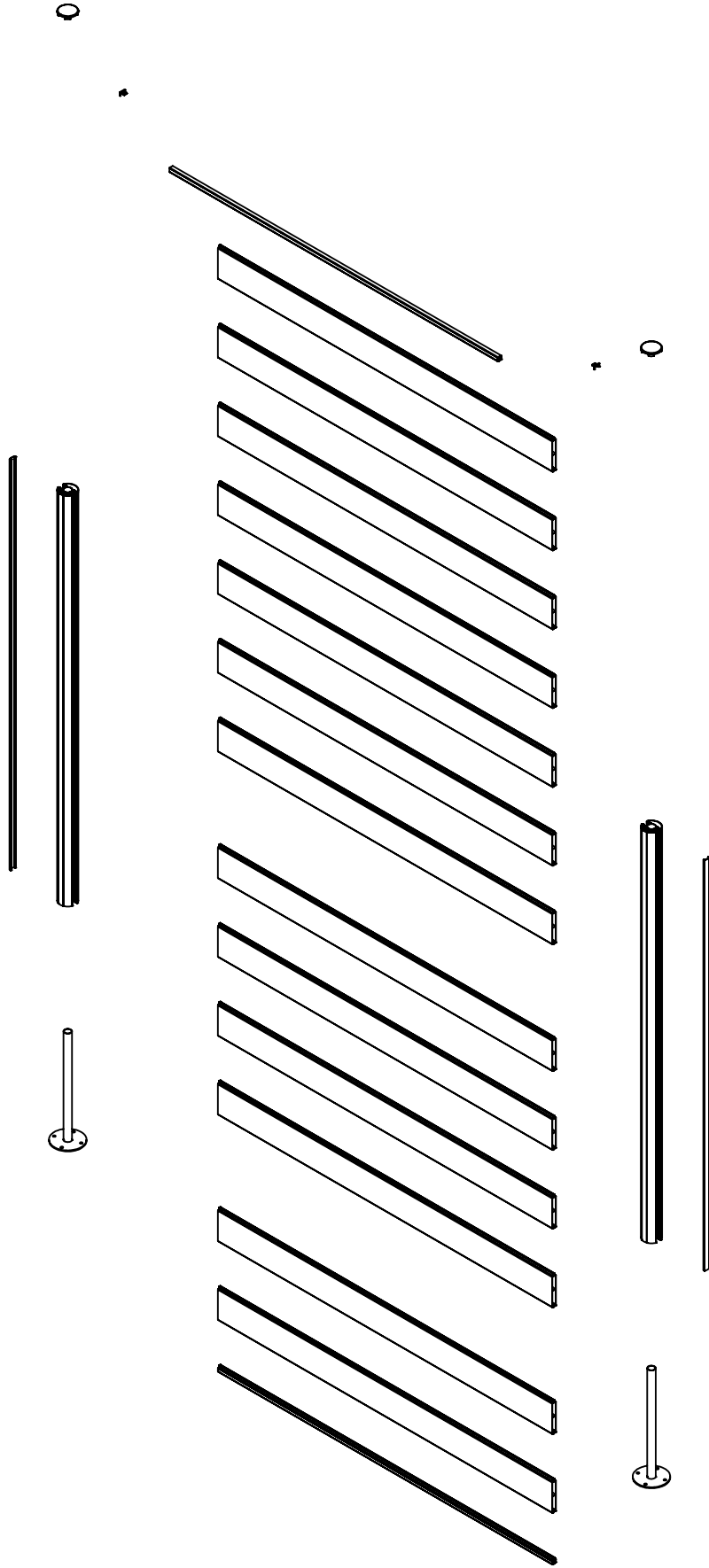
DIN 7168 TS 1980				NAME / İSİM	TARİH DATE	İMZA SIGNATURE	ÜRÜN KODU PRODUCT CODE	150 ALM 8888		
TOLERANS KALİTESİ TOLERANCE CLASS				ÇİZEN DRAWN BY	M.YILMAZTÜRK	9.08.2024	ÜRÜN ADI PRODUCT NAME			
BOYUTLAR DIMENSIONS	f (ince) f (fine)	m (orta) m (medium)	g (kaba) g (coarse)	KONTROL CHECKED BY	H.YILDIZ	9.08.2024	PARÇA KODU PART CODE	150 ALM 8888		
0.5-3 mm	±0.05	±0.1	±0.2	ONAY APPROVED BY	H.YILDIZ	9.08.2024	PARÇA ADI PART NAME	Genel Montaj		
3-6 mm	±0.05	±0.1	±0.3	Teknik Resim Kodu		PAGE/SAYFA	MALZEME MATERIAL	YÜZEY ALANI mm² SURFACE AREA mm²	21640410.64	SCALE/ÖLÇEK
6-30 mm	±0.1	±0.2	±0.5			1	Malzeme <belirli değil>	AĞIRLIK (gr) MASS (gr)	16096.35	1:50
30-120 mm	±0.15	±0.3	±0.8							
120-400 mm	±0.2	±0.5	±1.2							
400-1000 mm	±0.3	±0.8	±2.0							
1000-2000mm	±0.5	±1.2	±3.0							



DIN 7168 TS 1980				NAME / İSİM	TARİH DATE	İMZA SIGNATURE	ÜRÜN KODU PRODUCT CODE	150 ALM 8888		
TOLERANS KALİTESİ TOLERANCE CLASS				ÇİZEN DRAWN BY	23.09.2024		ÜRÜN ADI PRODUCT NAME			
BOYUTLAR DIMENSIONS	f (ince) f (fine)	m (orta) m (medium)	g (kaba) g (coarse)	KONTROL CHECKED BY	23.09.2024		PARÇA KODU PART CODE	150 ALM 8888		
0.5-3 mm	±0.05	±0.1	±0.2	ONAY APPROVED BY	23.09.2024		PARÇA ADI PART NAME	Genel Montaj		
3-6 mm	±0.05	±0.1	±0.3	Teknik Resim Kodu		PAGE/SAYFA	MALZEME MATERIAL	YÜZEY ALANI mm² SURFACE AREA mm²	21637115.34	SCALE/ÖLÇEK
6-30 mm	±0.1	±0.2	±0.5	152 XXX YYYY REV00		1	Malzeme <belirli değil>	AĞIRLIK (gr) MASS (gr)	16404.60	1:100
30-120 mm	±0.15	±0.3	±0.8							
120-400 mm	±0.2	±0.5	±1.2							
400-1000 mm	±0.3	±0.8	±2.0							
1000-2000mm	±0.5	±1.2	±3.0							

# Nr. 7 Upper closing profile

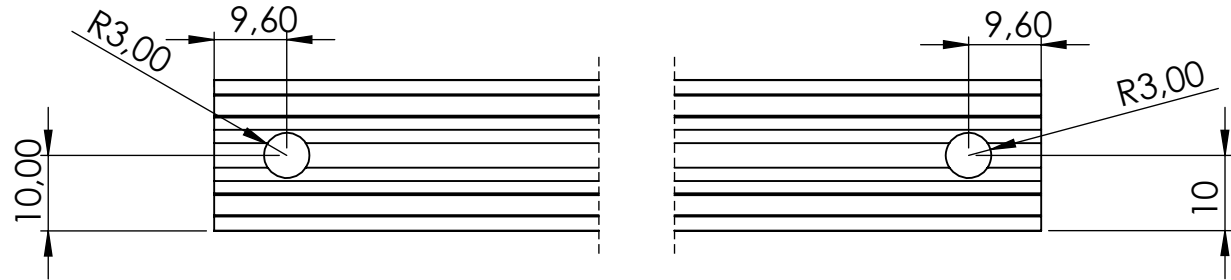
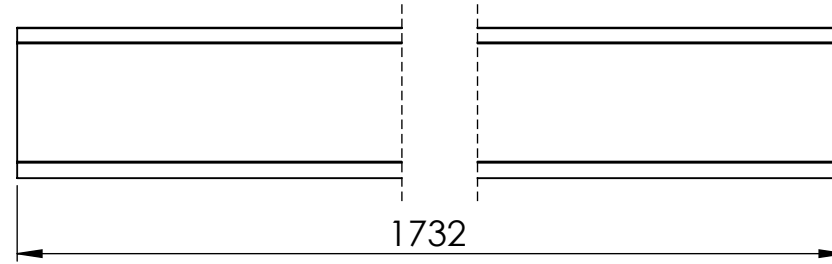
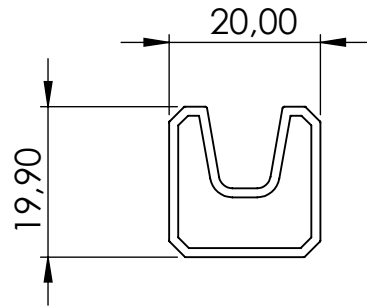
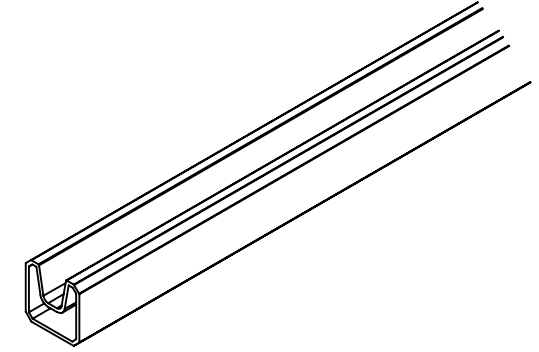



DIN 7168 TS 1980				NAME / İSİM	TARİH DATE	İMZA SIGNATURE	ÜRÜN KODU PRODUCT CODE				
TOLERANS KALİTESİ TOLERANCE CLASS				ÇİZEN DRAWN BY	M.YILMAZTÜRK	24.09.2024		ÜRÜN ADI PRODUCT NAME			
BOYUTLAR DIMENSIONS	f (ince) f (fine)	m (orta) m (medium)	g (kaba) g (coarse)	KONTROL CHECKED BY	H.YILDIZ	24.09.2024		PARÇA KODU PART CODE			
0.5-3 mm	±0.05	±0.1	±0.2	ONAY APPROVED BY	H.YILDIZ	24.09.2024		PARÇA ADI PART NAME			
3-6 mm	±0.05	±0.1	±0.3	Teknik Resim Kodu		PAGE/SAYFA	MALZEME MATERIAL	YÜZEY ALANI mm² SURFACE AREA mm²	303901.80	SCALE/ÖLÇEK	
6-30 mm	±0.1	±0.2	±0.5			1	6063-T5	AĞIRLIK (gr) MASS (gr)	492.34	1:20	
30-120 mm	±0.15	±0.3	±0.8								
120-400 mm	±0.2	±0.5	±1.2								
400-1000 mm	±0.3	±0.8	±2.0								
1000-2000mm	±0.5	±1.2	±3.0								

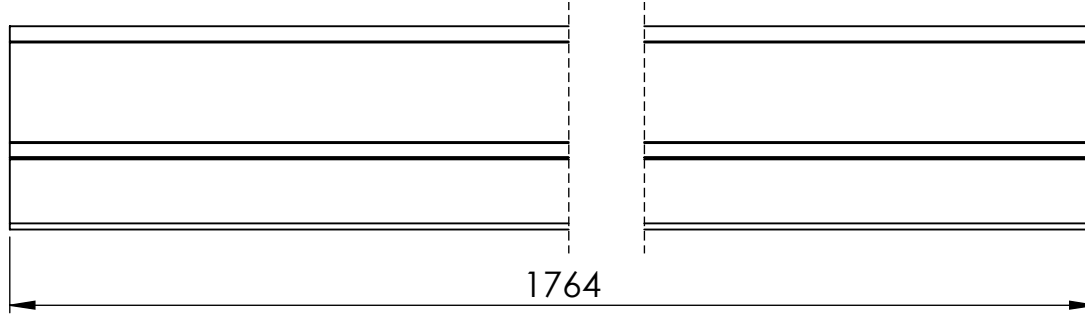
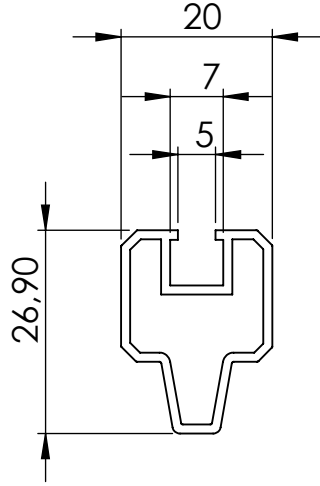
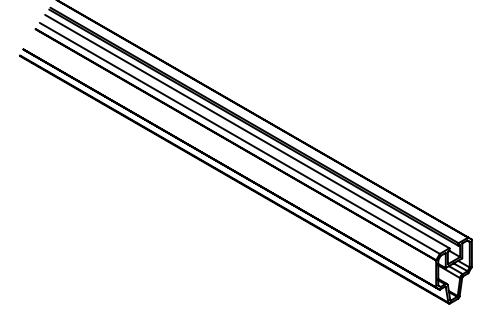

4050-Yuvarlak İç Ayaklı Model 1 Çit Üst Çita - 2

# Nr. 3 Bottem profile

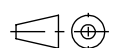

DIN 7168 TS 1980				NAME / İSİM	TARİH DATE	İMZA SIGNATURE	ÜRÜN KODU PRODUCT CODE			
TOLERANS KALİTESİ TOLERANCE CLASS				ÇİZEN DRAWN BY	M.YILMAZTÜRK	24.09.2024		ÜRÜN ADI PRODUCT NAME		
BOYUTLAR DIMENSIONS	f (ince) f (fine)	m (orta) m (medium)	g (kaba) g (coarse)	KONTROL CHECKED BY	H.YILDIZ	24.09.2024		PARÇA KODU PART CODE		
0.5-3 mm	±0.05	±0.1	±0.2	ONAY APPROVED BY	H.YILDIZ	24.09.2024		PARÇA ADI PART NAME		4051- Çit Ara Çita
3-6 mm	±0.05	±0.1	±0.3	Teknik Resim Kodu		PAGE/SAYFA	MALZEME MATERIAL		YÜZEY ALANI mm² SURFACE AREA mm²	345288.90
6-30 mm	±0.1	±0.2	±0.5			1	6063-T5		AĞIRLIK (gr) MASS (gr)	560.85
30-120 mm	±0.15	±0.3	±0.8						SCALE/ÖLÇEK	1:20
120-400 mm	±0.2	±0.5	±1.2							
400-1000 mm	±0.3	±0.8	±2.0							
1000-2000mm	±0.5	±1.2	±3.0							

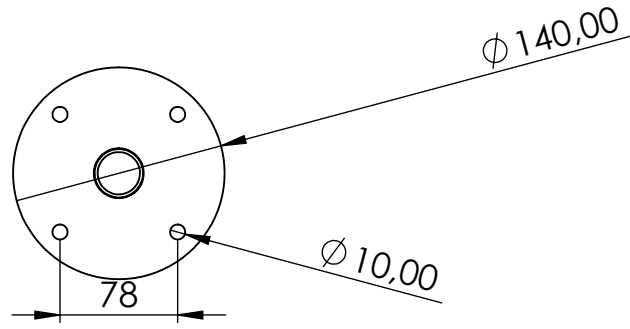

Nr. 1 Round post Leg (Anchor)

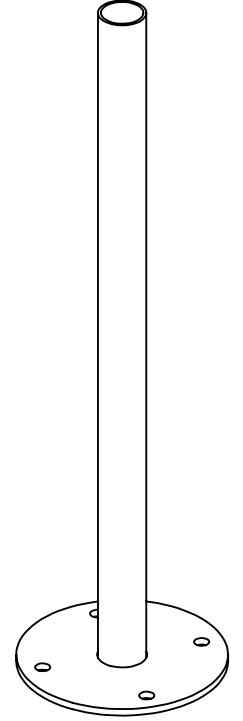
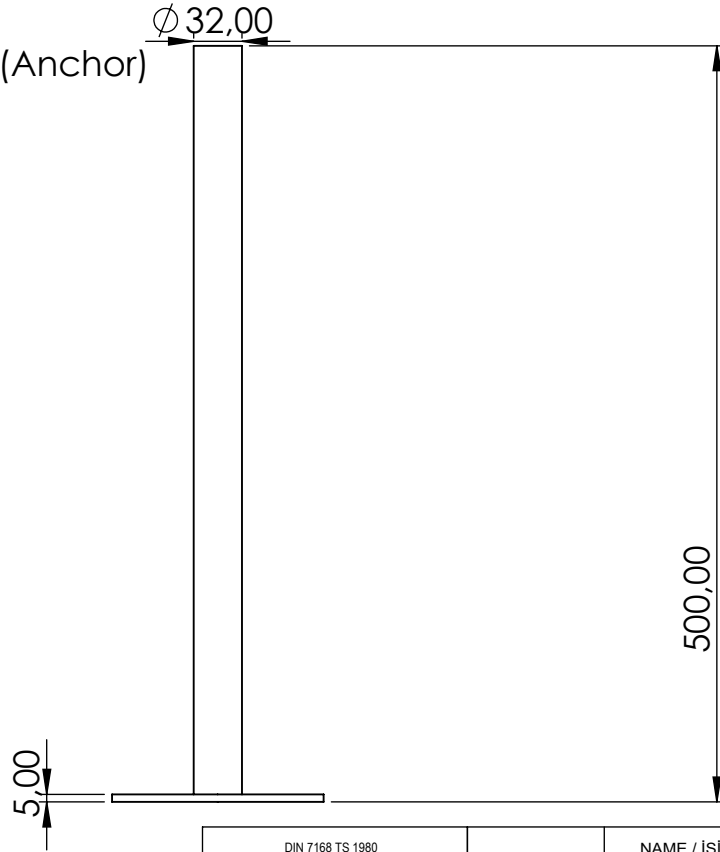

DIN 7168 TS 1980				NAME / İSİM	TARİH DATE	İMZA SIGNATURE	ÜRÜN KODU PRODUCT CODE				
TOLERANS KALİTESİ TOLERANCE CLASS				ÇİZEN DRAWN BY	Mehmet YILMAZTÜRK	9.08.2024		ÜRÜN ADI PRODUCT NAME			
BOYUTLAR DIMENSIONS	f (ince) f (fine)	m (orta) m (medium)	g (kaba) g (coarse)	KONTROL CHECKED BY	H.YILDIZ	9.08.2024		PARÇA KODU PART CODE			
0.5-3 mm	±0.05	±0.1	±0.2	ONAY APPROVED BY	H.YILDIZ	9.08.2024		PARÇA ADI PART NAME	ANKRAJ MONTAJ		
3-6 mm	±0.05	±0.1	±0.3	Teknik Resim Kodu		PAGE/SAYFA	MALZEME MATERIAL	YÜZEY ALANI mm² SURFACE AREA mm²	126419.26	SCALE/ÖLÇEK	1:10
6-30 mm	±0.1	±0.2	±0.5			1	Malzeme <belirli değil>	AĞIRLIK (gr) MASS (gr)	165.37		
30-120 mm	±0.15	±0.3	±0.8								
120-400 mm	±0.2	±0.5	±1.2								
400-1000 mm	±0.3	±0.8	±2.0								
1000-2000mm	±0.5	±1.2	±3.0								



# Nr. 8 Clips for 4050 upper closing profile

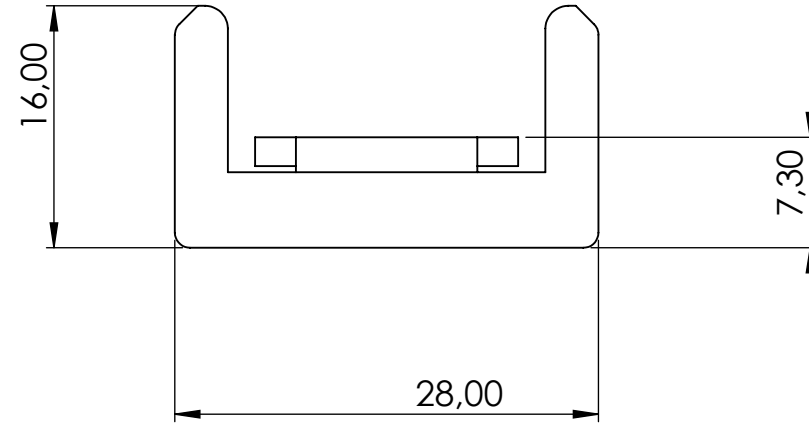
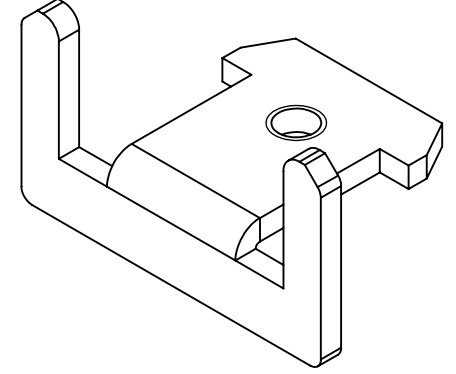
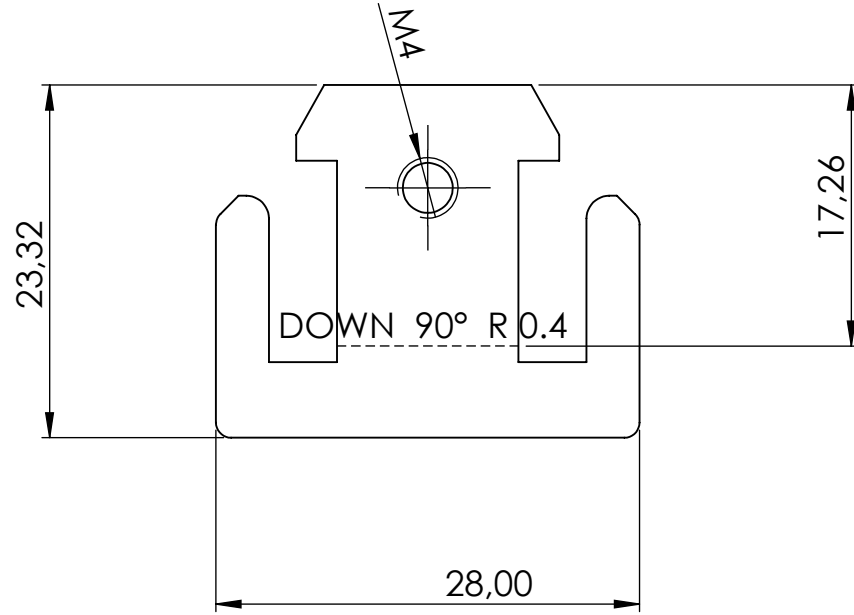

DIN 7168 TS 1980				NAME / İSİM	TARİH DATE	İMZA SIGNATURE	ÜRÜN KODU PRODUCT CODE		
TOLERANS KALİTESİ TOLERANCE CLASS				ÇİZEN DRAWN BY	23.09.2024		ÜRÜN ADI PRODUCT NAME		
BOYUTLAR DIMENSIONS	f (ince) f (fine)	m (orta) m (medium)	g (kaba) g (coarse)	KONTROL CHECKED BY	23.09.2024		PARÇA KODU PART CODE		
0.5-3 mm	±0.05	±0.1	±0.2	ONAY APPROVED BY	23.09.2024		PARÇA ADI PART NAME		
3-6 mm	±0.05	±0.1	±0.3	Teknik Resim Kodu		PAGE/SAYFA	MALZEME MATERIAL	YÜZEY ALANI mm² SURFACE AREA mm²	SCALE/ÖLÇEK
6-30 mm	±0.1	±0.2	±0.5			1		AĞIRLIK (gr) MASS (gr)	2:1
30-120 mm	±0.15	±0.3	±0.8						
120-400 mm	±0.2	±0.5	±1.2						
400-1000 mm	±0.3	±0.8	±2.0						
1000-2000mm	±0.5	±1.2	±3.0						

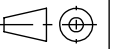



Nr. 4 Round post chanel cover

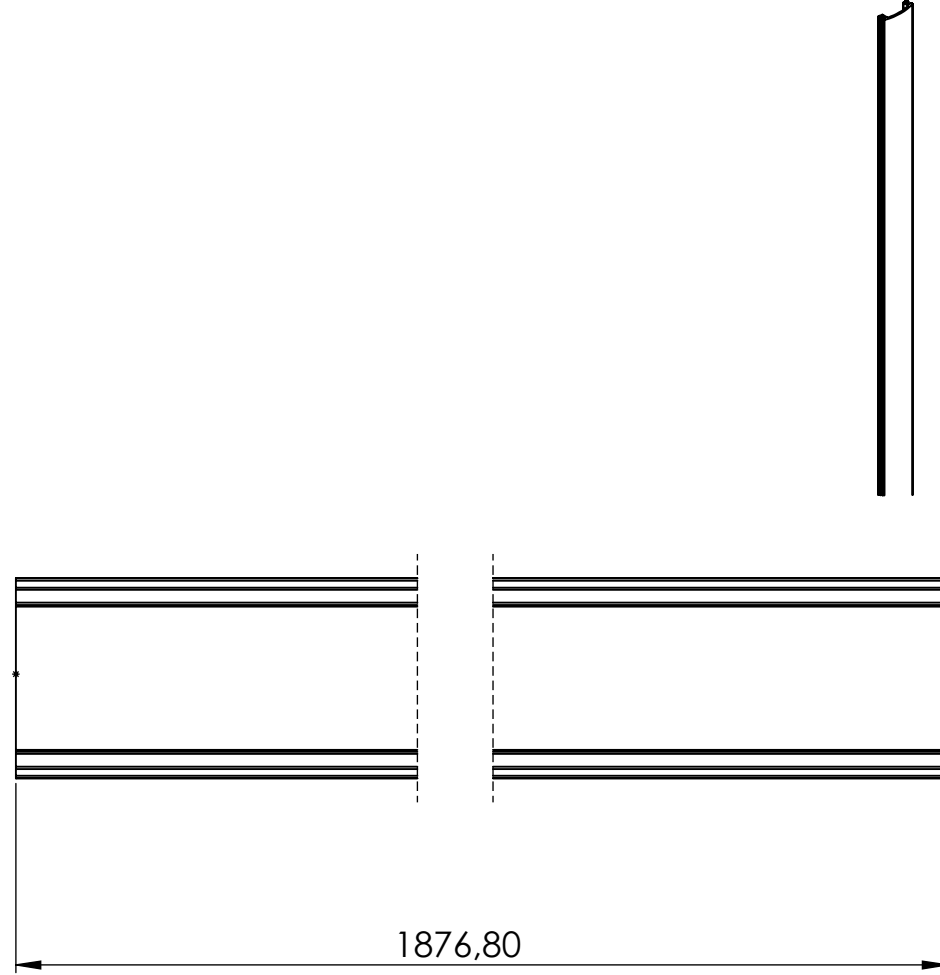
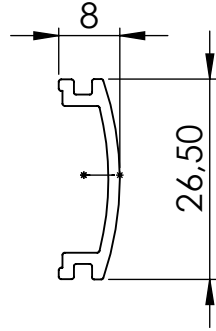

DIN 7168 TS 1980				NAME / İSİM	TARİH DATE	İMZA SIGNATURE	ÜRÜN KODU PRODUCT CODE		
TOLERANS KALİTESİ TOLERANCE CLASS				ÇİZEN DRAWN BY	M.YILMAZTÜRK	24.09.2024	ÜRÜN ADI PRODUCT NAME		
BOYUTLAR DIMENSIONS	f (ince) f (fine)	m (orta) m (medium)	g (kaba) g (coarse)	KONTROL CHECKED BY	H.YILDIZ	24.09.2024	PARÇA KODU PART CODE		
0.5-3 mm	±0.05	±0.1	±0.2	ONAY APPROVED BY	H.YILDIZ	24.09.2024	PARÇA ADI PART NAME	4075-Çit Ayak Uzun Kapak	
3-6 mm	±0.05	±0.1	±0.3	Teknik Resim Kodu		PAGE/SAYFA	MALZEME MATERIAL	YÜZEY ALANI mm² SURFACE AREA mm²	153948.75
6-30 mm	±0.1	±0.2	±0.5			1	6063-T5	AĞIRLIK (gr) MASS (gr)	316.83
30-120 mm	±0.15	±0.3	±0.8					SCALE/ÖLÇEK	1:20
120-400 mm	±0.2	±0.5	±1.2						
400-1000 mm	±0.3	±0.8	±2.0						
1000-2000mm	±0.5	±1.2	±3.0						



Nr. 6 Blind profile (lambiri)

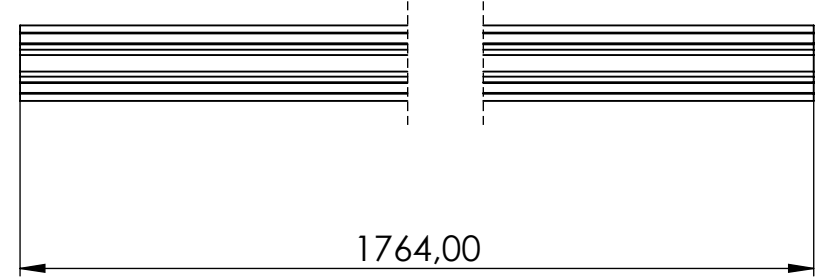
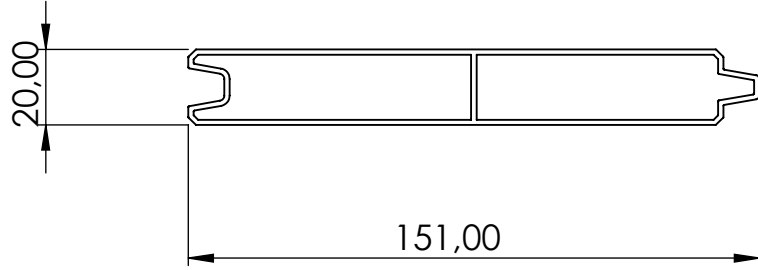
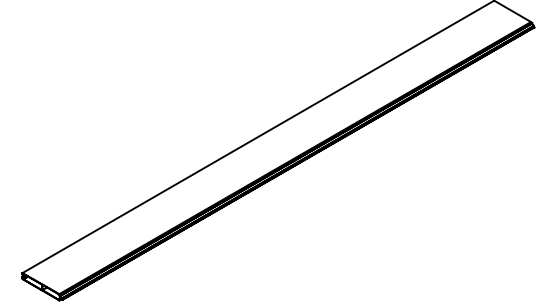

DIN 7168 TS 1980				NAME / İSİM	TARİH DATE	İMZA SIGNATURE	ÜRÜN KODU PRODUCT CODE		
TOLERANS KALİTESİ TOLERANCE CLASS				ÇİZEN DRAWN BY	M.YILMAZTÜRK	24.09.2024	ÜRÜN ADI PRODUCT NAME		
BOYUTLAR DIMENSIONS	f (ince) f (fine)	m (orta) m (medium)	g (kaba) g (coarse)	KONTROL CHECKED BY	H.YILDIZ	24.09.2024	PARÇA KODU PART CODE		
0.5-3 mm	±0.05	±0.1	±0.2	ONAY APPROVED BY	H.YILDIZ	24.09.2024	PARÇA ADI PART NAME	4052- Lambirili Çit Panel	
3-6 mm	±0.05	±0.1	±0.3	Teknik Resim Kodu		PAGE/SAYFA	MALZEME MATERIAL	YÜZEY ALANI mm² SURFACE AREA mm²	1268954.59
6-30 mm	±0.1	±0.2	±0.5			1	6063-T5	AĞIRLIK (gr) MASS (gr)	2417.74
30-120 mm	±0.15	±0.3	±0.8					SCALE/ÖLÇEK	1:20
120-400 mm	±0.2	±0.5	±1.2						
400-1000 mm	±0.3	±0.8	±2.0						
1000-2000mm	±0.5	±1.2	±3.0						

Nr. 5 Round post with connection channels

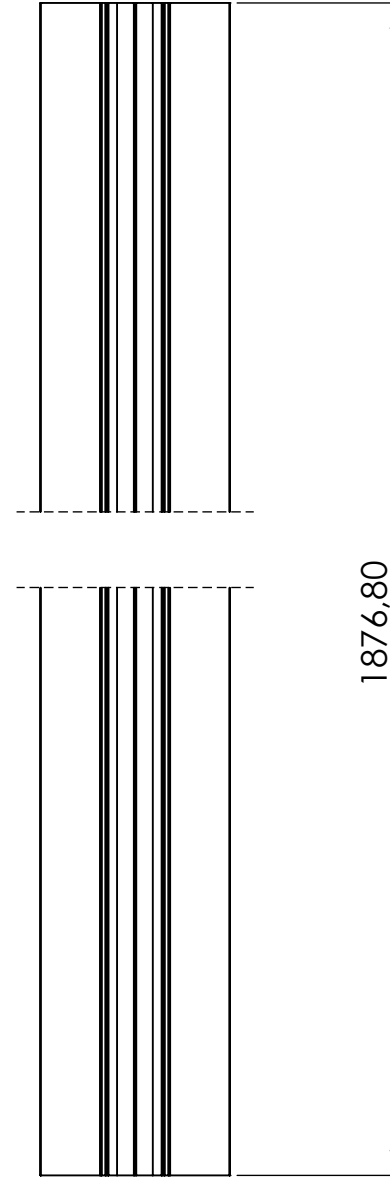
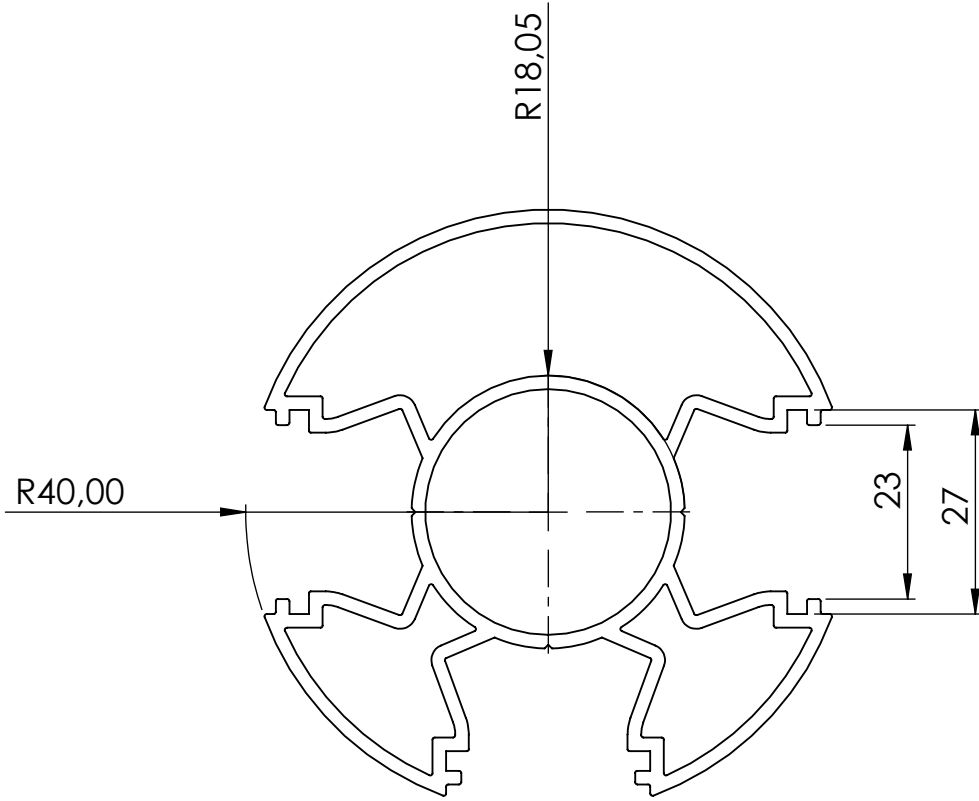

DIN 7168 TS 1980				NAME / İSİM	TARİH DATE	İMZA SIGNATURE	ÜRÜN KODU PRODUCT CODE				
TOLERANS KALİTESİ TOLERANCE CLASS				ÇİZEN DRAWN BY	M.YILMAZTÜRK	24.09.2024	ÜRÜN ADI PRODUCT NAME				
BOYUTLAR DIMENSIONS	f (ince) f (fine)	m (orta) m (medium)	g (kaba) g (coarse)	KONTROL CHECKED BY	H.YILDIZ	24.09.2024	PARÇA KODU PART CODE				
0.5-3 mm	±0.05	±0.1	±0.2	ONAY APPROVED BY	H.YILDIZ	24.09.2024	PARÇA ADI PART NAME	4072- Yuvarlak İç Ayaklı Model 1 Çit Ayak			
3-6 mm	±0.05	±0.1	±0.3	Teknik Resim Kodu		PAGE/SAYFA	MALZEME MATERIAL	YÜZEY ALANI mm² SURFACE AREA mm²	1622875.97	SCALE/ÖLÇEK	1:20
6-30 mm	±0.1	±0.2	±0.5			1	6063-T5	AĞIRLIK (gr) MASS (gr)	4046.58		
30-120 mm	±0.15	±0.3	±0.8								
120-400 mm	±0.2	±0.5	±1.2								
400-1000 mm	±0.3	±0.8	±2.0								
1000-2000mm	±0.5	±1.2	±3.0								

